

# 01-PLAN VIEW

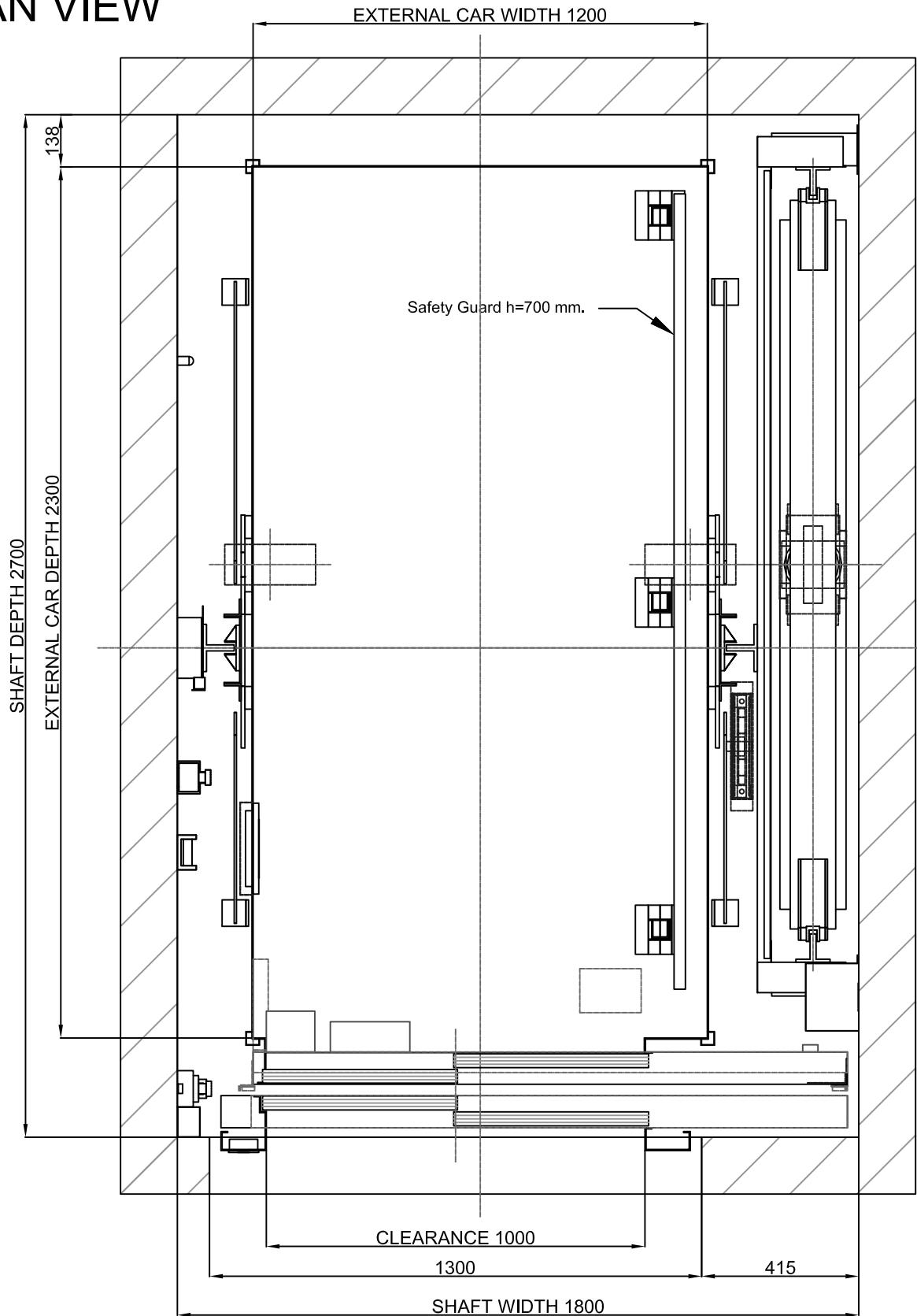
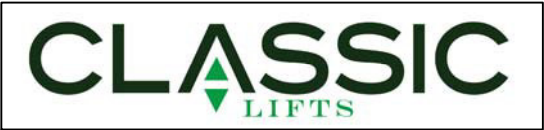

DO NOT SCALE

DRAWING	DATE	REV.	SHEET	[*] Unbounded dimensions in drawings are indicative and not binding.
		00	1	REFERENCE: MPGO!EVOLUTION630ST2_EN
MODEL LIFT:				CLIENT: WORK SITUATION:
CLASSIC LIFTS - EVOLUTION				
CAPACITY: [N° PERSONS]	17			
NOMINAL LOAD: [kg]	1275			
SPEED: [m/s]	1			
FREQUENCY: [Hz]	50			
TENSION: [V]	400V [Three-phase]			

# 05-PIT LAYOUT

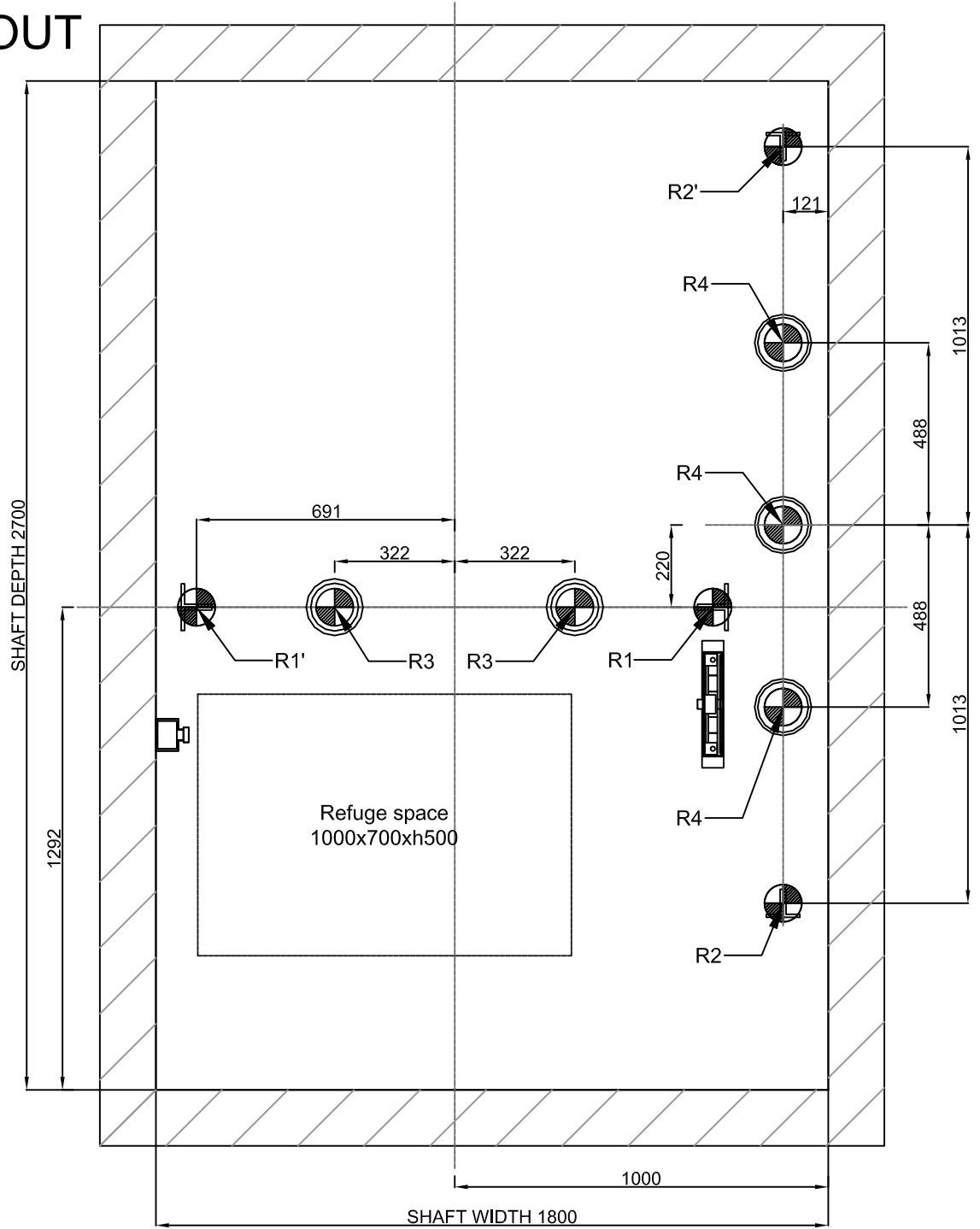

DO NOT SCALE

REACTIONS [N] [max.]					
R1	26700	R2	27500		
R1'	26700	R2'	27500		
R3	54400	R4	27800		
Sx	1560	Sy	920		

DRAWING	DATE	REV.	SHEET	[*] Unbounded dimensions in drawings are indicative and not binding.
		00	1	REFERENCE: MPGO!EVOLUTION630ST2_EN
MODEL LIFT:				CLIENT: WORK SITUATION:
CLASSIC LIFTS - EVOLUTION				
CAPACITY: [N° PERSONS]		17		
NOMINAL LOAD: [kg]		1275		
SPEED: [m/s]		1		
FREQUENCY: [Hz]		50		
TENSION: [V]		400V [Three-phase]		

# 02-SIDE VERTICAL SECTION

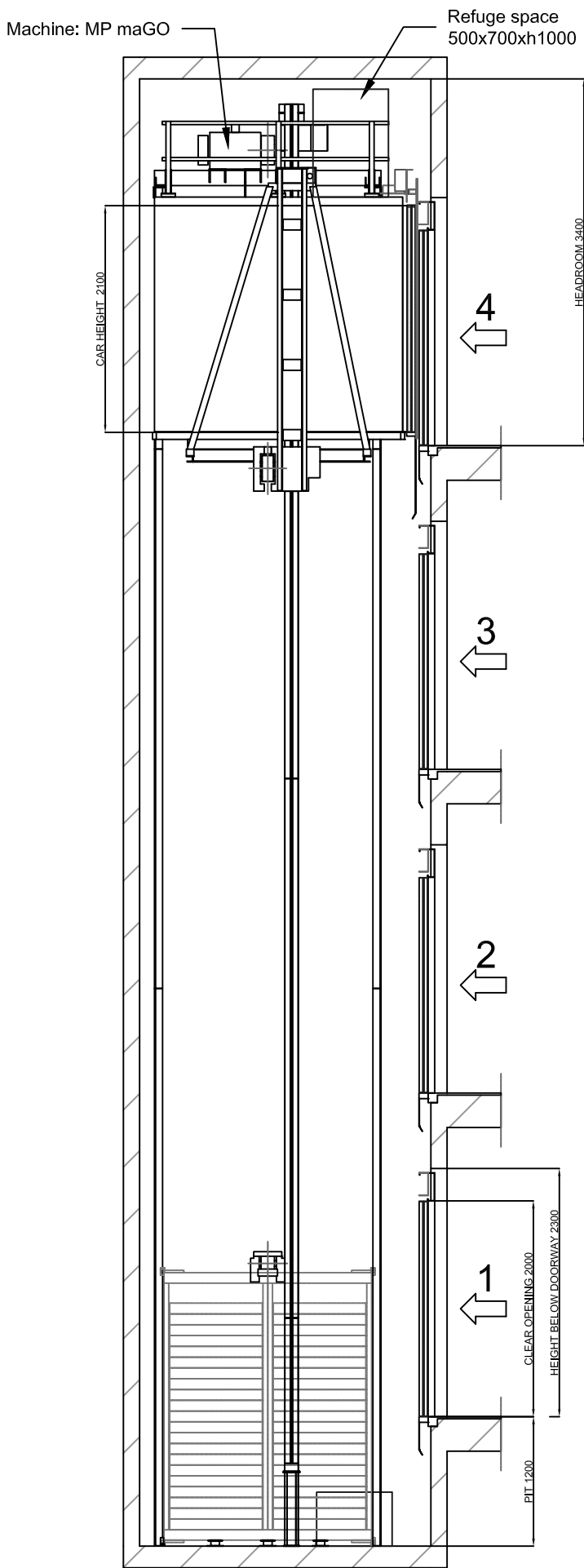

DO NOT SCALE

[\*] Unbounded dimensions in drawings are indicative and not binding.

REFERENCE:

MPGO!EVOLUTION630ST2\_EN

CLIENT:

WORK SITUATION:

**CLASSIC**  
LIFTS

DRAWING	DATE	REV.	SHEET
		00	2
MODEL LIFT:			
<b>CLASSIC LIFTS - EVOLUTION</b>			
CAPACITY: [N° PERSONS]			17
NOMINAL LOAD: [kg]			1275
SPEED: [m/s]			1
FREQUENCY: [Hz]			50
TENSION: [V]			400V [Three-phase]

Flat and levelled floor, protected against water leaking.

[EN81-20:2014 5.2.1.9]

Foresee pit access device

[EN81-20:2014 5.2.2.4]

Stop device

[EN81-20:2014 5.2.1.5.1. a]

Inspection control station.

[EN81-20:2014 5.2.1.5.1. b]

Power supply

[EN81-20:2014 5.2.1.5.1. c]

Light swicht

commuted with the cabinet.

[EN81-20:2014 5.2.1.5.1. d]